



Operation and Maintenance Manual for the  
SODRTEK®  
ST 125 Soldering System  
P/N 5050-0534



TITLE	PAGE
General Information .....	3
Introduction.....	3
Specifications .....	3
Parts Identification.....	4
Safety Guidelines .....	5
System Set-Up .....	6
Tip & Tool Stand.....	6
Handpiece Connection .....	6
TEKLINK.....	6
System Power Up .....	7
Burn In Procedure .....	7
Operation.....	7
Tip Offset .....	7
Variable Temperature Control .....	8
Temperature/Dial Lock .....	8
LED Operation .....	8
Temperature Dial Adjustment .....	8
Vacuum Pump Operation .....	9
Handpiece Vacuum Pressure .....	9
Corrective Maintenance .....	10
Power Source .....	10
Handpieces.....	10
Packing List.....	11
Spare Parts .....	11
Service .....	11
“SODRTEK by PACE” LIMITED WARRANTY STATEMENT.....	12
Contact Information.....	13

## **General Information**

### **Introduction**

Thank you for purchasing the PACE SODRTEK® model ST 125 Analog Desoldering System. This manual will provide you with the information necessary to properly set up, operate and maintain the ST 125.

The ST 125 system is available in either 115 VAC or 230 VAC versions, which incorporates a highly responsive SensaTemp (closed loop) control system providing up to 80 Watts of total power to a single output channel. The 230 VAC version system bears the CE Conformity Marking, which assures the user that it conforms to EMC 89/336/EEC.

The 115 VAC version systems conform to FCC Emission Control Standard, Title 47, Subpart B, Class A. This standard is designed to provide reasonable protection against harmful interference when the equipment is operated in a commercial environment.

### **Specifications**

#### **System Power Source Power Requirements**

ST 125	Operates on 97-127 VAC, 50/60Hz, 90 Watts maximum at 115 VAC, 60Hz
ST 125E	Operates on 197-253 VAC 50/60Hz, 80 Watts maximum at 230 VAC, 50Hz

#### **Temperature Specifications**

Handpieces	Tip Temperature Range: 204 to 455°C (400 to 850°F) nominal. Temperature Stability: ±1.1°C (±2°F) at idle from set tip temp.
------------	--------------------------------------------------------------------------------------------------------------------------------

**NOTE:** Actual minimum and maximum Operating Tip Temperatures may vary depending on Handpiece, Tip Selection and application.

#### **Vacuum And Air**

Measurements at front panel Vacuum and Controllable Pressure Ports.  
Vacuum Rise Time: ----- 150 ms average.  
Vacuum: ..... 51 cm Hg. (20 in. Hg.) (nominal)  
Pressure: ..... 1.44 Bar (21 P.S.I.) (nominal at MAX setting)  
Air Flow: ..... 6 SLPM (0.22 SCFM) maximum

#### **EOS/ESD Specifications**

The specifications shown below apply except on "Soft Ground Systems" which have a 1meg ohm current limiting resistance and a label placed on the power source front panel referring to EN 100015-1.

Tip-To-Ground Resistance: Less than 2 ohms.  
AC Leakage: Less than 2 Millivolts RMS from 50Hz to 10MHz.  
Transient Level: Less than 500mV peak, out to 100MHz.

## Parts Identification

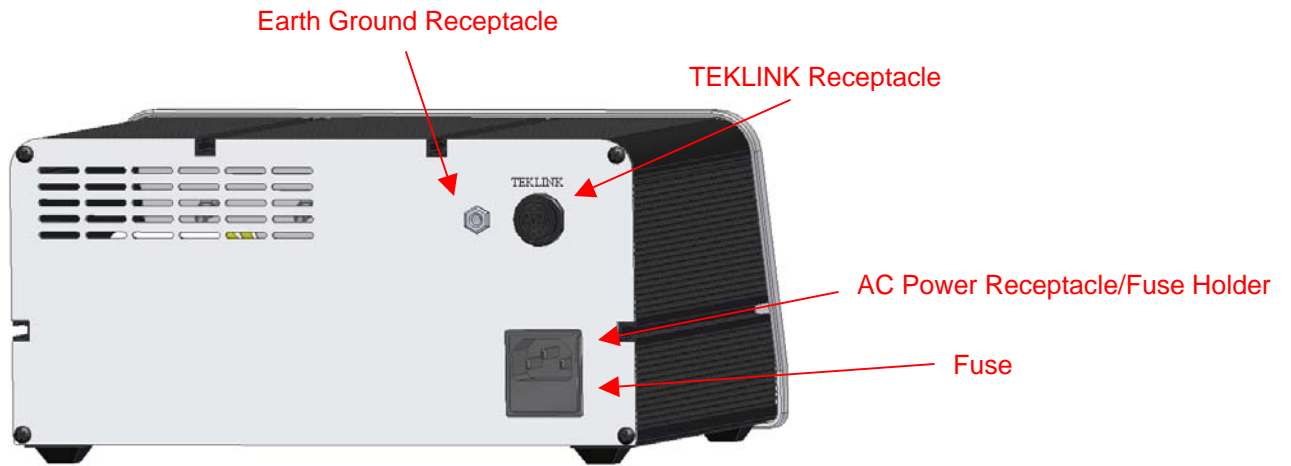
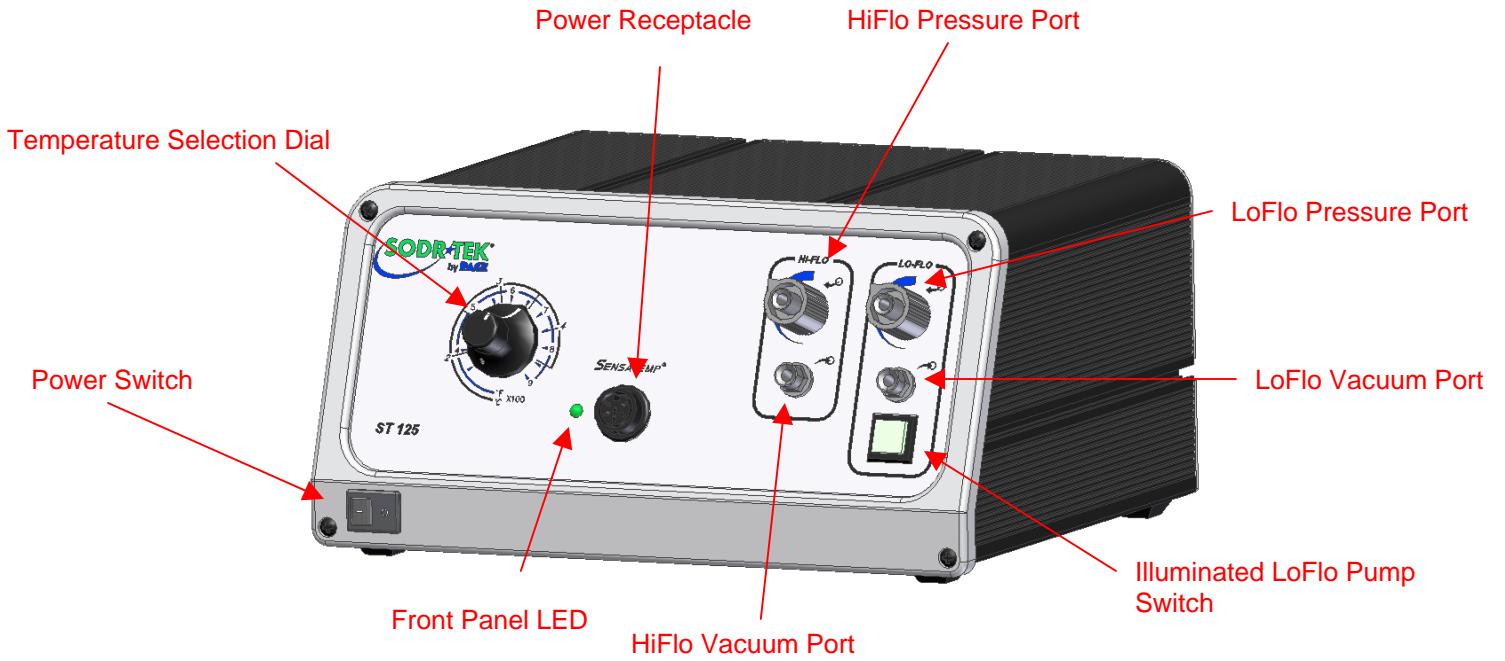

## **Safety Guidelines**

The following are safety precautions that personnel must understand and follow when using or servicing this product.

1. **POTENTIAL SHOCK HAZARD** - Repair procedures on PACE products should be performed by Qualified Service Personnel only. Line voltage parts may be exposed when the equipment is disassembled. Service personnel must avoid contact with these parts when troubleshooting the product.
2. To prevent personnel injury, adhere to safety guidelines in accordance with OSHA and other applicable safety standards.
3. SensaTemp handpiece heaters and installed tips are hot when the handpiece is powered on and for a period of time after power off. **DO NOT** touch either the heater or the tip. Severe burns may result.
4. PACE Tip & Tool Stands and handpiece cubbies are designed specifically for use with the associated handpiece and houses it in a manner that protects the user from accidental burns. Always store the handpiece in its holder. Be sure to place the handpiece in its holder after use and allow for cooling before storing.
5. Always use PACE systems in a well ventilated area. A fume extraction system such as those available from PACE are highly recommended to help protect personnel from solder flux fumes.
6. Exercise proper precautions when using chemicals (e.g., solder paste). Refer to the Material Safety Data Sheet (MSDS) supplied with each chemical and adhere to all safety precautions recommended by the manufacturer.

## System Set-Up

Set up the ST 125 system using the following steps and associated drawings.

1. Store the shipping container in a convenient location. Reuse of these containers will prevent damage if you store or ship your system.
2. Place the Power Switch in the "OFF" or "0" position.



### Tip & Tool Stand

The Tip & Tool Stand can be mounted to the power source. If the system will be placed on the workbench, this is recommended. If the ST 125 is to be mounted under the workbench or shelf, the Tip & Tool Stand should not be mounted to the power source.

1. To attach the stand to the power source:
  - a) Insert the 2 Mounting Screws (head first) into the power source mounting slots (plastic case shown). Slide the screws toward rear of the power source.
  - b) Place the Tip & Tool Stand beside the power source. Insert ends of the 2 Mounting Screws into the 2 Tip & Tool Stand mounting holes as shown.
  - c) Install a Thumb Nut onto the end of each Mounting Screw and tighten Thumb Nuts.
2. Place the handpiece into its Tip & Tool Stand.

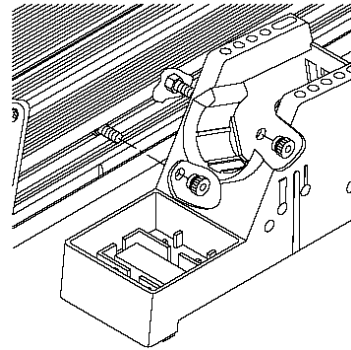

### Handpiece Connection

Connect the handpiece connector plug into the Power Receptacle in the following manner.

1. Align guide on connector with slot on power receptacle.
2. Insert connector into power receptacle.
3. Turn the connector housing clockwise to lock in place.

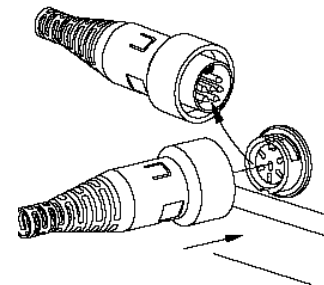

### TEKLINK

The TEKLINK receptacle located on the back panel of the power supply allows you to interface the **VACUUM** and **PRESSURE** features of your ST 125/145 with the SodrTek ST 25/45 system. This feature gives you the freedom to operate air-controlled handpieces (SX-70/80, TP-65, or TJ-70/80) from an ST 25/45 system through the **VACUUM** and **PRESSURE** ports of your ST 125/145. To link your ST 125 system to the ST 25/45 system, perform the following procedure.

1. Place the ST 25/45 system adjacent to (side by side) or stacked on top of your ST 125/145 system.
2. Use the TEKLINK cable (sold separately) to connect the systems together. The TEKLINK Receptacle is located on the back panel of each power supply.

### TEKLINK Receptacle



3. Ensure the VisiFilter assembly is connected to either the ST 125/145 **VACUUM** Port.
4. Connect the air hose of the handpiece being used, to either the VisiFilter assembly or the controllable **PRESSURE** port.

The TEKLINK Remote Box (sold separately) allows the connection of up to three ST 25/45 systems in any combination.

**NOTE:** Systems connected together through the TEKLINK system must be used and controlled by a single operator. Any attempt to operate by more than one individual can create a hazardous condition and will cause deterioration in performance.

### **System Power Up**

1. Insert the female end of the power cord into the AC Power Receptacle on the rear panel of the power source.
2. Plug the prong end (male end) of the power cord into an appropriate 3 wire grounded AC supply receptacle.

**CAUTION:** To insure operator and ESD/EOS safety, the AC power supply receptacle must be checked for proper grounding before initial operation.

### **Heater Burn In Procedure**

Use the following instructions to perform the Heater Burn In procedure.

1. Place the Power Switch in the "OFF" (0) position.
2. Ensure that the handpiece is connected to the power source. If a plastic cap is present on the heater assembly, remove it and discard. The cap is used for shipping purposes only. Place the handpiece in the Tip & Tool Stand.
3. Turn on the power source.
4. Turn the Temperature dial to 315°C (600 °F) for 10 minutes.
5. Next, increase the temperature to 427°C (800°F) for 15 minutes.
6. Turn off the power source.

**CAUTION:** The heater will be hot at the conclusion of the Burn In procedure.

**NOTE:** This procedure should be performed whenever a new handpiece or new heater is connected to the system. Ensure that the system is placed in a well-ventilated area. Smoke will be generated during the burn in cycle and while soldering. Fume extraction equipment is recommended.

### **Operation**

#### **Tip Offset**

Differences between the temperature settings and true tip temperatures are negligible when using Thru-Hole, single point soldering tips. With any heating system however, True Tip Temperatures can differ greatly from temperature settings when using larger SMT soldering tips. This difference is called Tip Temperature Offset. PACE recommends the use of the Tip & Temperature Selection

System booklet (PACE P/N 5050-0251) as a guide to accurately set and maintain a true tip temperature for any size and type of SMT tip.

### Variable Temperature Control

Adjust the Variable Temperature Control Knob to the desired temperature setting. Notice that the control panel has an outer graphic scale denoting temperature in °C (Celsius) and an inner graphic scale denoting temperature in °F (Fahrenheit). These numerical scales denote the set tip temperature times 100 (e.g., "3" on the outer scale is 3 x 100 or 300°C).

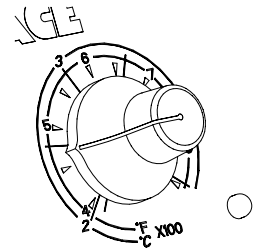

### Temperature/Dial Lock

The Variable Temperature Control Knob can be locked in position to avoid accidental or unauthorized changes of the temperature setting.

1. Adjust the Temp. Control Knob to the desired temperature setting.
2. Using the Temp. Locking Key (hex key supplied with system), tighten the set screw on the Temp. Locking Ring closest to the front panel.

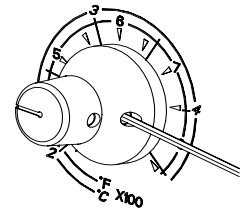

### LED Operation

The Green colored LED on the power source front panel indicates System Status and Power Receptacle output status (LED OFF, ON or Flashing).

**LED Full On** - Continuous power is being delivered to the handpiece. This condition is evident when the system is first powered up (handpiece heater cold) or the Variable Temperature Control setting is increased.

**LED Flashing** - Indicates that the set tip temperature (as set on the Variable Temperature Control) has been reached. Power to the handpiece is cycling Off and On to maintain set temperature.

**LED Off** - No power is being delivered to the handpiece heater. This condition is evident for a short period of time when set temperature is reached and stabilizing or if the Variable Temperature Control setting is decreased. If the LED never illuminates, check for a faulty handpiece (see Corrective Maintenance section). Also, if no handpiece is connected to the power source, the LED will not illuminate.



### Temperature Dial Adjustment

The ST 125 system is tested for temperature accuracy at the factory and can be checked for calibration according to PACE requirements. Also, a temperature setting normally used by the operator can be adjusted to the precise temperature indicated on the Dial/Display. No internal adjustments can be made to the power supply. To verify calibration of the Temperature selection dial, perform the following procedure.

1. Install a tip with an embedded thermocouple into the handpiece connected to the system. Tips with K type thermocouples are available from PACE.
2. Connect the thermocouple assembly to an appropriate temperature meter.
3. When set fully counterclockwise, the pointer of the Variable Temperature Control knob will align to the Calibration Mark as shown. With the system turned on, adjust the Variable Temperature Control to obtain a stable tip temperature of 300°C (for

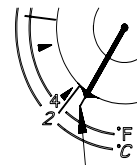



PACE factory specifications) or the temperature setting normally used by the operator. If the temperature displayed on temperature meter is within  $\pm 15^{\circ}\text{C}$  ( $27^{\circ}\text{F}$ ), perform steps 4 thru 6 to obtain a precise reading. If the temperature is off by more than  $\pm 15^{\circ}\text{C}$ , the handpiece may require maintenance. Recheck the temperature using a second handpiece.

4. Carefully lock the Variable Temperature Control in position by tightening the inner set screw (closest to front panel).
5. Loosen the outer set screw on the Variable Temperature Control knob (furthest from front panel) using the Temp. Locking Key (hex key) supplied with the system. Position the knob with the pointer aligned to match the temperature indicated on the temperature meter. Secure the knob in position by tightening the outer set screw. Loosen the inner set screw to unlock the Variable Temperature control if adjustment of operating tip temperature is desired.

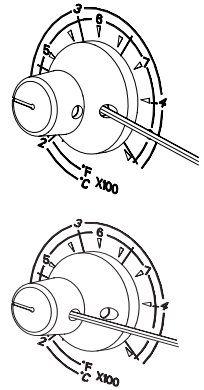

### Vacuum Pump Operation

The PACE ST 125 contains two different vacuum pumps.

1. HiFlo Pump
  - a) To activate, depress the handpiece activation button.
  - b) Optional Foot Pedal can be used to actuate the HiFlo pump via the rear TEKLINK socket.
2. LoFlo Pump
  - a) This pump is activated by the front Illuminated LoFlo Pump Switch.
  - b) Used for the TJ-70/80 and PV-65 Pik Vac Wand.

**CAUTION:** Ensure that only one air hose is connected to the **VACUUM** or controllable **PRESSURE** port at one time. Attachment to both ports simultaneously will cause deterioration in performance.

### Handpiece Vacuum/Pressure

To set up your Sodr-X-Tractor air hose connection, perform the following steps:

1. Air Hose To Handpiece Connection:
  - a) Attach one end of a 137cm (54 inch) length of air hose to the metal tube in the back of the handpiece.
  - b) If you have a PACE system incorporating only one handpiece, attach the air hose to the power cable using the supplied Hose Clamps. Space them evenly along the length of the power cable starting at a point 6 inches from the ends of the handpiece.
  - c) If you have a PACE system incorporating 2 or more air handpieces, you may wish to leave the air hose assembly unattached to allow a quick change to any air handpiece being used.
2. Prepare a VisiFilter in the following manner:

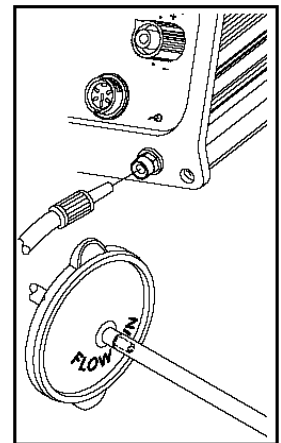

- a) Connect a 1 inch (2.5cm) length of clear pvc air hose to the FLOW OUT side of the VisiFilter; push and turn the hose onto the VisiFilter nipple to seat.
  - b) Insert the ribbed end of a male quick connect hose mount fitting (P/N 1259-0087) into the free end of the 1 inch (2.5cm) length of air hose connected to the FLOW OUT side of the VisiFilter.
  - c) Connect the free end of the 137cm (54 inch) length of air hose to the FLOW IN side of the VisiFilter.
  - d) Insert the end of the quick connect hose mount fitting (on VisiFilter FLOW OUT side) into the power source Vacuum Port.
3. When using air pressure, and/or utilizing multiple air handpieces, PACE recommends the use of the following set up procedure which utilizes additional quick connect hose mount fittings. An assortment of quick connect air fittings are supplied with each additional air handpiece.
- a) Disconnect the 137cm (54 inch) length of air hose from the FLOW IN side of the VisiFilter assembly. Insert the ribbed end of a male quick connect hose mount fitting (P/N 1259-0087) into the free end of this air hose.
  - b) Connect the free end of a 1 inch (2.5cm) length of air hose with an installed female quick connect hose mount fitting (P/N 1259-0086) to the FLOW IN side of the VisiFilter Assembly.
  - c) The 137cm (54 inch) length of air hose can now be easily moved between the VisiFilter Assembly and the Controllable Pressure Port. The VisiFilter assembly remains connected to the Vacuum Port.
4. Additional fittings may also be added to the hose connection at the rear of each air handpiece to ease changing of handpieces.

**NOTE:** When removing any air hose, turn and pull. Do not attempt to pull hose directly off. Damage to or breakage of fitting or VisiFilter may occur. Use your Sodr-X-Tractor with a clean VisiFilter element. Otherwise a deterioration in performance or damage to the unit may occur.

## **Corrective Maintenance**

### **Power Source**

Refer to the table below. Most malfunctions are simple and easy to correct.

<b>Symptom</b>	<b>Probable Cause</b>	<b>Solution</b>
No power to system	Blown Fuse	Check handpiece using the appropriate handpiece manual. Replace the fuse (located in the AC Receptacle Fuse Holder) with one of the same rated value.
Handpiece will not heat	Defective Heater	Refer to the appropriate handpiece manual
	Power Source Malfunction	Contact PACE

## Handpieces

Please refer to the specific handpiece manual for the "Heater Assembly Checkout Procedures."

## Packing List

Item #	Description	Part Number	ST 125 Only	ST 125 E Only
1	System Power Supply		1	0
2	System Power Supply (Export)		0	1
3	Power Cord, 115V	1332-0094	1	0
4	Power Cord, 230V	1332-0093	0	1
5	Hex Key, .050	1100-0237	1	1
6	Operations Manual CD	CD5050-0459	1	1

## Spare Parts

Item #	Description	PACE Part Number
1	Fuse, 1.25 Amp, 250 V, Time Lag (ST 125)	1159-0251-P5
	Fuse, 0.63 Amp, 250 V, Time Lag (ST 125E)	1159-0252-P5
2	Tip & Temperature Selection Chart	5050-0251
3	TEKLINK Cable	1332-0252-P1
4	TEKLINK Remote Box	3008-0218-P1

## Service

Please contact PACE or your local distributor for service and repair.

**“SODRTEK by PACE” LIMITED WARRANTY STATEMENT**

**Limited Warranty**

Seller warrants to the first user that products manufactured by it and supplied hereunder are free of defects in materials and workmanship for a period of one (1) year from the date of receipt by such user. Monitors, computers and other brand equipment supplied but not manufactured by PACE are covered under their respective manufacturer's warranty in lieu of this Warranty.

This warranty does not cover wear and tear under normal use, repair or replacement required as a result of misuse, improper application, mishandling or improper storage. Consumable items such as tips, heaters, filters, etc. which wear out under normal use are excluded. Failure to perform recommended routine maintenance, alterations or repairs made other than in accordance with Seller's directions, or removal or alteration of identification markings in any way will void this warranty. This warranty is available only to the first user, but the exclusions and limitations herein apply to all persons and entities.

**SELLER MAKES NO OTHER WARRANTY, EXPRESS OR IMPLIED, AND MAKES NO WARRANTY OF MERCHANTABILITY OR FITNESS FOR A PARTICULAR PURPOSE.**

Seller will, at its option, repair or replace any defective products at its facility or other location approved by it at no charge to user, or provide parts without charge for installation by the user in the field at user's expense and risk. User will be responsible for all costs of shipping equipment to Seller or other location for warranty service.

**EXCEPT FOR THE REMEDY ABOVE DESCRIBED, UNLESS OTHERWISE REQUIRED BY APPLICABLE LAW, SELLER WILL HAVE NO OTHER OBLIGATION WITH REGARD TO ANY BREACH OF WARRANTY OR OTHER CLAIM WITH RESPECT TO THE PRODUCTS, OR LIABILITY FOR ANY DIRECT, INDIRECT, CONSEQUENTIAL, OR INCIDENTAL LOSS OR DAMAGE CAUSED BY OR OCCURRING IN CONNECTION WITH ANY OF THE PRODUCTS.**

Warranty service may be obtained by contacting the appropriate PACE Company or local Authorized PACE distributor as set forth below to determine if return of any item is required, or if repairs can be made by the user in the field. Any warranty or other claim with respect to the products must be made with sufficient evidence of purchase and date of receipt, otherwise user's rights under this warranty shall be deemed waived.

For PACE USA Customers:

PACE, INCORPORATED  
9030 Junction Drive  
Annapolis Junction, Maryland 20701  
Tel. 301-317-3588  
FAX. 301-498-3252

For PACE EUROPE Customers:

PACE EUROPE LIMITED  
Sherbourne House, Sherbourne Drive,  
Tilbrook, Milton Keynes  
MK7 8HX  
United Kingdom  
Tel. (44) 1908 277666  
WARRANTY SERVICE FAX: (44) 1908 277 777

All other Customers:

Local Authorized PACE Distributor

PACE Incorporated retains the right to make changes to specifications contained herein at any time, without notice. Contact your local authorized PACE Distributor or PACE Incorporated to obtain the latest specifications.

The following are trademarks and/or service marks of PACE, Incorporated, MD, USA:

INSTACAL™, FUMEFLO™, HEATWISE™, PACEWORLDWIDE™, PERMAGROUND™, POWERPORT™, POWERMODULE™, TEMPWISE™, TIP-BRITE™, AUTO-OFF™, and TEKLINK™.

The following are registered trademarks and/or service marks of PACE Incorporated, Annapolis Junction Maryland U.S.A.

ARM-EVAC®, FLO-D-SODR®, MINIWAVE®, PACE®, SENSATEMP®, SNAP-VAC®, SODRTEK®, SODR-X-TRACTOR®, THERMOFLO®, THERMOJET®, THERMOTWEEZ®, VISIFILTER®, THERMO-DRIVE®, and TOOLNET®.

PACE products meet or exceed all applicable military and civilian EOS/ESD, temperature stability and other specifications including MIL STD 2000, ANSI/JSTD 001, IPC7711, and IPC A-610.



[www.paceworldwide.com](http://www.paceworldwide.com)

**PACE USA**

9030 Junction Drive  
Annapolis Junction, MD 20701  
USA

Tel: (301) 490-9860

Fax: (301) 498-3252

**PACE Europe**

Sherbourne House  
Sherbourne Drive  
Tilbrook, Milton Keynes  
MK7 8HX  
United Kingdom

(44) 01908-277666

(44) 01908-277777